

<b>NMRA Technical Note</b>	
<b>Layout Command Control<sup>®</sup> (LCC)</b>	
<b>Datagram Transport</b>	
<b>Feb 6, 2016</b>	<b>TN-9.7.3.2</b>

## Adopted as a NMRA Technical Note

The OpenLCB Standard document appended to this cover sheet has been formally adopted as a NMRA Standard by the NMRA Board of Directors on the date shown in the *Adopted* column in the *Version History* table below.

### 5 Version History

Date	Adopted	Summary of Changes
Feb 17, 2015		Initial version submitted for public comment
Feb 6, 2016	<b>Feb 20, 2016</b>	Minor grammatical corrections and readability improvements as well as the following specific changes: <ul style="list-style-type: none"> <li>• <b>4.3 Datagram Rejected</b></li> <li>• <b>4.3.1 Error Codes</b></li> <li>• <b>6.1 Normal Transmission</b></li> <li>• <b>6.2 Rejected Transmission</b></li> <li>• <b>7.1 CAN Message Formats</b></li> <li>• <b>7.2 CAN States</b></li> <li>• <b>7.3.1 Normal Transmission</b></li> <li>• <b>7.3.2 Rejected Transmission</b></li> </ul>

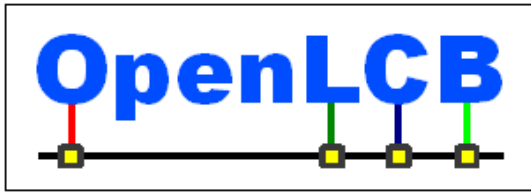

## OpenLCB Technical Note

### Datagram Transport

Feb 6, 2016

Adopted

## 1 Introduction

This Technical Note contains informative discussion and background for the corresponding “OpenLCB Datagram Transport Standard”. This explanation is not normative in any way.

5 Some wire protocols can support only very short packets/frames, e.g. CAN with a limited header and data payload. OpenLCB needs to be able to move larger chunks of data than that. OpenLCB streaming provides a very large payload, at some cost in setup time and complexity. “Datagrams” move an amount of data in-between “small enough to always be atomic” and “large enough to justify streaming overhead”.

10 The datagram protocol on CAN links uses the same structure as the common protocol, except for the need to split the message into frames.

A node may only send one datagram at a time to any given destination node. A node may interleave transmission of datagrams to separate nodes, but this is not recommended because the longer transmission window increases the probability of buffer collisions in recipient nodes.

## 2 Annotations to the Standard

15 This section provides background information on corresponding sections of the Standard document. It is expected that these two documents will be read together.

### 2.1 Introduction

[Intentionally left blank]

### 2.2 Intended Use

20 [Intentionally left blank]

### 2.3 References and Context

For more information on format and presentation, see:

- Common Information Technical Note

### 2.4 Message Formats

#### 25 2.4.1 Datagram Content

The datagram length is coded by the transport medium: There is no separate length field in the datagram content itself.

30 The datagram Content ID in the 1<sup>st</sup> byte of the datagram content is meant to make it easier for node software to sort out how to handle individual datagrams. This makes it possible for multiple protocols to be using datagrams to communicate between two nodes independently. The figure shows an example of that.

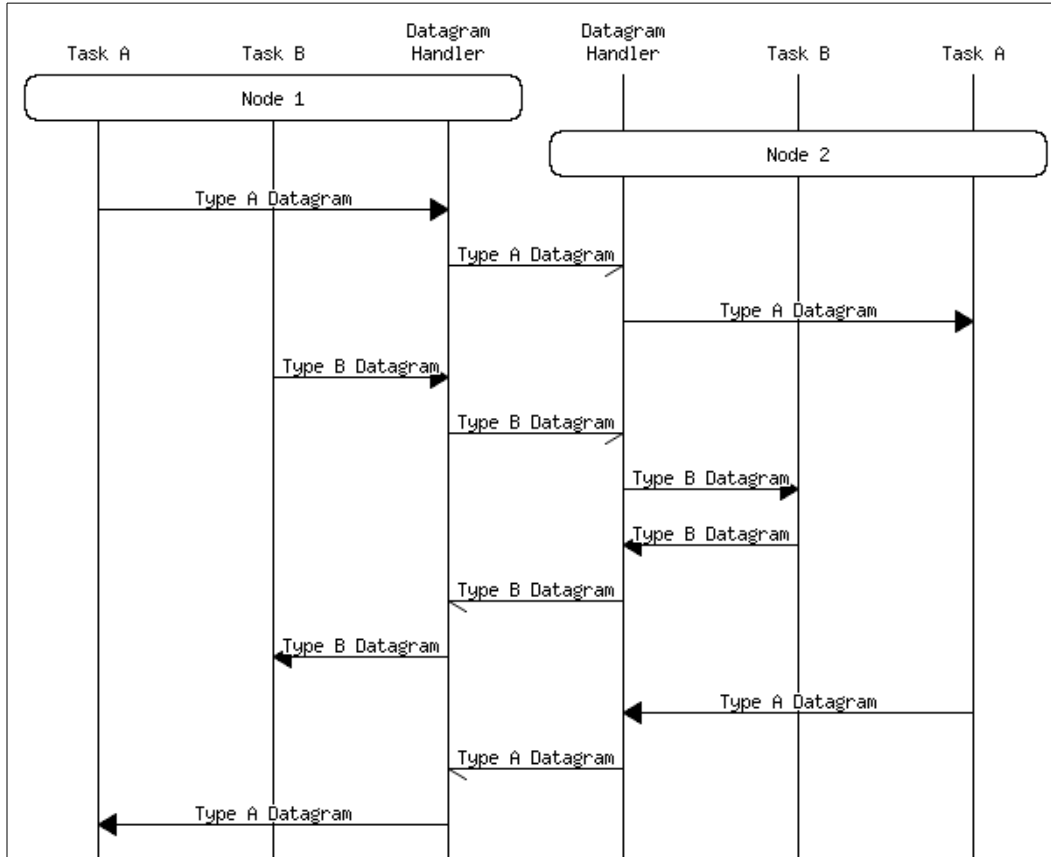

**Datagram type allows general datagram handler to dispatch datagrams to proper handlers without having to track conversation state or understand details of datagram-using protocols.**

35 Note that zero-length datagrams are valid. They don't contain a Content ID, so can only be used in certain circumstances.

### 2.4.2 Datagram Received OK

This is an addressed message. The destination address (full Node ID or alias) can be taken directly from the received Datagram Content message.

Nodes are required to handle a missing Datagram Received OK flag byte for backwards compatibility.

40 When a datagram contains a command within some higher-level protocol, it's very convenient to have a way to signify success of that operation without having to send an additional datagram as a reply. The Reply Pending bit can be used to to that. It's not understood in any way by the datagram protocol itself, just passed through. Some possible approaches include:

- Don't use it at all. There are no replies to operations.
- 45 • Don't use it at all. Each operation consists of a command datagram, and some other message or datagram in reply.

- When the operation usually succeeds immediately, that success can be signaled by the Datagram Received OK message. Delayed success or failure can then be signaled by Datagram Received OK with the Reply Pending bit set, followed by a later datagram or message that carries the completion message. The Reply Pending bit then tells the datagram originator whether the operation is done, or whether it needs to wait for a further reply.

The Timeout Value field can be used by higher-level protocols to provide feedback on how long an operation will take. This could be used to provide a progress indicator or trip an error recovery operation when needed. A zero value, the default with nothing is provided, means no information. The higher level protocol that defines use of the datagram should define how to recover from timeout errors.

### 2.4.3 Datagram Rejected

This is an addressed message. The destination address (full Node ID or alias) can be taken directly from the received Datagram Content message.

Rejecting datagrams is meant for cases where the actual transmission and reception of the datagram has failed. It's not meant for higher level errors, such as "The command to move the points did not succeed because they were stuck". The decision whether to reply with Datagram Received OK or Datagram Rejected needs to be made promptly, so that the reply can be sent, buffers can be cleared and communications can continue.

#### 2.4.3.1 Error Codes

In general, errors are of one of two types:

- "Permanent error" — This node does not process datagrams, will not accept a datagram from this source, or for some other reason will not ever be able to accept this particular datagram. The datagram should not be retransmitted.
- "Resend OK" — In contrast to the error above, the problem accepting the datagram is of a transient nature, and the sending node should attempt retransmission at its discretion at some point in the immediate to near future.

The standard is written to allow for the case where neither is set if the node doesn't have a clear idea how to handle the error, but this is an undesirable case.

The Message Network Standard contains error codes for several conditions that may be useful for the Datagram implementations:

"Source not permitted" (0x1020) — Datagrams from this source will never be accepted. This error might be used to indicate that a receiving node is only willing to establish a connection with an exclusive set of nodes that doesn't include the sender.

"Not implemented, datagram type unknown" (0x1042) — This node will not accept datagrams of this type under any circumstance. If the node implements the Datagram Transport protocol, it should use this to reject datagrams that it cannot process because they are of an unknown type. Rejecting the interaction with an Optional Interaction Rejected message (see "OpenLCB Message Network Standard") should only be used by nodes that don't implement the Datagram Transport protocol (suggested error code 0x1043) because it carries the notion that the Datagram Protocol isn't supported.

“Transport Error” — Something appears to have gone wrong between the sender and the recipient, perhaps because the recipient received datagram fragments out of order (0x204x), or a sequence of datagrams was received out of order (at the application layer).

90 “Buffer shortage” (0x202x) - The node wasn't able to receive the datagram because of a shortage of buffers. This can happen during normal operation due to overlapping traffic to a node. Setting this error helps diagnose when datagram traffic is overwhelming the node's ability to buffer and process it.

“Out of Order” (0x204x) - Should not happen, but an internal inconsistency was found in the OpenLCB message sequence and/or in the CAN frames making up a datagram.

95 The bits 0-3 can be used for code for the specific condition that lead the receiving node to reject the Datagram Content message, as specified by the Message Network Standard. This is a good idea, because it helps debug persistent problems. Node manufacturers are encouraged to use the specific error codes, where applicable, or request defining new specific error codes from the OpenLCB group when they have a need not yet covered.

## 2.5 States

100 A datagram receive buffer is a form of state information, in that it's either full with a message being processed, or empty and ready to accept a new datagram. The protocols are written so that implementations can use just one buffer, or many. Depending on the connection to the physical OpenLCB network being used, it may be possible for overlapping reception of datagrams. This works even with one buffer, because datagrams that arrive while the first is still in process can be rejected temporarily. More buffers can make that more efficient.

Note that even in the presence of multiple buffers, overlapping multiple datagrams from the same source to the same destination is not allowed, because it is not possible to correctly attribute the Datagram Received OK / Datagram Rejected responses.

## 2.6 Interactions

110 A datagram is just a single message containing the Datagram MTI and the data byte(s). There is a convention for a data format indicator (Content ID) at the start of the data bytes for use with application layer protocols transported over datagrams, see Section 3.4 below.

### 2.6.1 Normal Transmission

115 Once the datagram has been successfully received, the receiving node replies to the original source node with a “Datagram Received OK” message. Note that the node is not required to examine or process the datagram before replying; execution errors that happen later are required to be signaled using another protocol.

120 The standard does not allow sending overlapping datagrams, but it is not specified what a node receiving overlapping datagrams must do. It is up to the implementation: the node may process both datagrams in the order as they arrived and generate multiple replies, or reject both datagrams. In other words, receiving nodes are not required to detect overlapping datagrams having been received.

### 2.6.2 Rejected Transmission

Instead of “Datagram Received OK”, the receiving node may return a “Datagram Rejected” message with an error code that represents the reason(s) and possible reaction(s).

125 There's no requirement for a specific response to out-of-spec Datagram Content messages. If a node receives out-of-spec datagram messages, such as one with too many bytes, what it does is up to the receiving node. This is because it is neither necessary nor practical to specify a unique set of logic for dealing with the semi-infinite number of possible out-of-spec transmissions. Nodes can use the various error replies to indicate whatever they know, but they don't have to.

## 130 **2.7 Adaptation to CAN Transport**

### **2.7.1 CAN Message Formats**

For CAN, the Datagram Content message is broken into a First frame, one or more Middle frames, and a Last frame. In the degenerate case of a very short message that can fit into one frame, there is also an Only frame. These are described in more detail below. The CAN header values are chosen to prevent  
135 CAN priority from reordering frames in a way that would damage the transmission.

- CAN-Datagram Content Single Frame — Note that zero-length datagrams are valid<sup>1</sup>.
- CAN-Datagram Content First Frame — Note that there's no requirement that this contain 8 bytes.
- CAN-Datagram Content Middle Frame — Note that there's no requirement that this contain 8  
140 bytes. It cannot be empty, though. This is to keep the total number of frames in a Datagram Content message bounded.
- CAN-Datagram Content Last Frame — Note that this frame can be zero length.

### **2.7.2 CAN States**

The CAN implementation allows more than one datagram to arrive at a node at the same time, since  
145 datagram fragments from node A and node B can arrive interleaved at their destination node C. Datagram implementations need to track this in their internal state. Approaches include:

- Having a single buffer, in which the fragments that go with the first-received Datagram Content First Frame are accumulated. Other datagrams can then be rejected immediately when their Datagram Content First Frame or Datagram Content Single Frame arrive.
- Having multiple buffers in which the datagrams are separately accumulated.  
150

Any implementation that obeys the protocol constraints in the Standard is acceptable.

### **2.7.3 CAN Interactions**

#### **2.7.3.1 Normal Transmission**

The sender breaks the datagram content into one or more frames. The source NodeID alias and  
155 destination NodeID alias are, unlike other addressed messages, both contained in the header. Format indicators are used to mark the segmentation into frames. The data part of the CAN frame can carry from zero to eight data bytes.

If there are more than eight bytes to the datagram, the rest are sent as consecutive frames. Because CAN transmission retains frame order between sender and receiver, no order information is added to

---

<sup>1</sup>However, zero-length datagrams will typically be rejected by most nodes that implement higher-level datagram-based protocols and use the first byte to determine the protocol used.

160 the frames. The first/middle/last frame is marked in the CAN header to aid in reconstruction of the full datagram in the buffer.

There's nothing in the Standard that says that CAN frames have to be maximal size. A 9-byte datagram can be frames of 8 and 1, or 1 and 8. This is helpful for handling, e.g., buffering and creation of dynamic content in the source node.

165 It is preferred that the frames making up a datagram be transmitted in a group, adjacent on the CAN bus. It is permitted to interrupt that to send higher-priority frames, either for CAN segment-level control, or for higher priority messages. It is not permitted to send lower priority frames, nor to interleave multiple datagrams, so that the buffering requirements at the receiving nodes stay bounded.

The receiving node receives the frames into a buffer. The frames from more than one datagram may  
170 arrive in interleaved order, in which case the receiving node can tell them apart using their source NodeID alias and store them in separate buffers. (Any given source node can only send a single datagram at a time to a single destination node.) If sufficient buffers are not available, the receiving node rejects the second datagram with a "Resend OK"-flagged error code. The reject message can be sent early, so that buffer space to accumulate the datagram or even state bits to remember there is a data  
175 need not be allocated. Once the "datagram complete" indicator (i.e., an Only datagram or Last datagram message) is received for a datagram, the node replies to the original source node with a "Datagram Received OK" or "Datagram Rejected" message.

The state machine for assembling datagram frames needs to know when the node Initialized state is reset so that it knows to abandon a partially received datagram. It can also recover upon seeing the  
180 next start/only frame or using a timeout mechanism.

An interface or gateway onto a CAN link must do the datagram fragmentation and defragmentation locally. Buffer retries may be either done locally by the gateway, or by reflecting the response back to the original sender.

### **2.7.3.2 Rejected Transmission**

185 Nodes are required to reject a certain set of out-of-spec transmissions. Nodes can use the specific error replies defined in the Message Network Standard to indicate whatever they know, but they don't have to.

Notice, however, that receiving a second valid datagram sequence from yet another node while receiving one (or more) that fills the local buffers is *not* an out-of-spec condition, and the protocol  
190 defines exactly how the node is to react. There's no flexibility in this case. The receiving node is required to send a Datagram Rejected message usually (but not necessarily) with the "Resend OK" error code.

## **3 Background Information**

### **3.1 Use Cases**

195 Here are some example application-level protocols that are or might be transported using datagrams.

- Memory configuration: Simple one-value reads and writes of configuration data are one-to-one operations that need to exchange 4-8-16-32 bytes of data.
- External-network control: If an OpenLCB segment is attached to single external networks, e.g. a DCC or LocoNet system, one-to-one transmission can be used to exchange native commands. E.g. “Send the following LocoNet message” may need to be up to 18 bytes long with current LocoNet definitions. Communication to LocoNet/DCC/etc. can be one-to-one to insure communications; return messages can be many one-to-one to listeners, but there's also a need for one-to-many or broadcast which is not addressed by the datagram transport.
- RFID: RFID tags carry 40-64 bits of payload. Adding in some status and location information, reporting an RFID tag requires a 8-16 byte payload, and that's likely to grow in the future.

## 3.2 Discussion

Datagrams are a one-to-one connection between nodes. They have a single source address and a single destination address, and only have to be delivered to that single destination. Delivery is guaranteed if the destination node is active, initialized and reachable, but it is not possible to guarantee in advance that a buffer is available in the destination to receive and assemble the datagram.

The datagram protocol does not require error correction, because OpenLCB is based only on reliable links, that is, links that guarantee no content or order errors. CAN, TCP/IP, etc., handle their own error correction. The datagram protocol needs flow control and synchronization, however, as a small node might not have resources to accumulate a large number of datagrams that are arriving in an interleaved order. The “Received OK” message is to inform small-capacity sending nodes that it can free its buffer holding the transmitted message.

On CAN links, the datagram protocol is constrained by the limited frame size. Datagrams must be broken into multiple frames for transfer. The protocol must allow for the possibility that datagrams to a particular node can be interleaved if several nodes are transmitting at the same time. Note that a node can control what it sends, so it is possible to ensure that only one datagram is being sent from a node at one time, just not that only one is being received.

The datagram content formats rely on CAN not reordering frames, even in the presence of error recovery. That's needed in any case for streams, which are so large that complete internal buffering cannot be assumed.

## 3.3 Examples

### 3.3.1 Normal CAN case



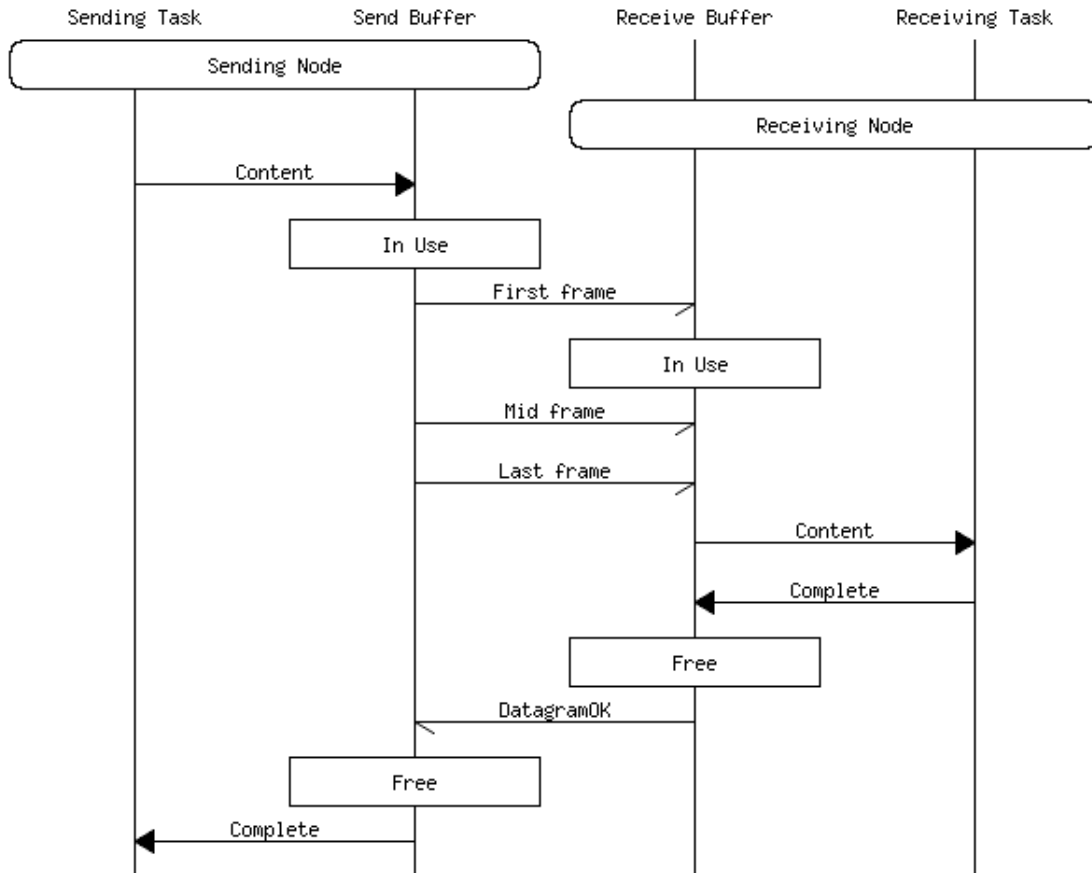

Transferring a datagram using three CAN frames. Note buffering.

230

**3.3.2 Short CAN datagram case**

Datagram Only Frame →  
 ← Datagram Received OK

**3.3.3 Rejected short CAN datagram case**

235 Even a short datagram can be rejected with a “Resend OK” if there's, e.g. a shortage of buffers:

Datagram Only Frame →  
 ← Datagram Rejected, Resend OK

### 3.3.4 Rejected interleaved CAN datagram case

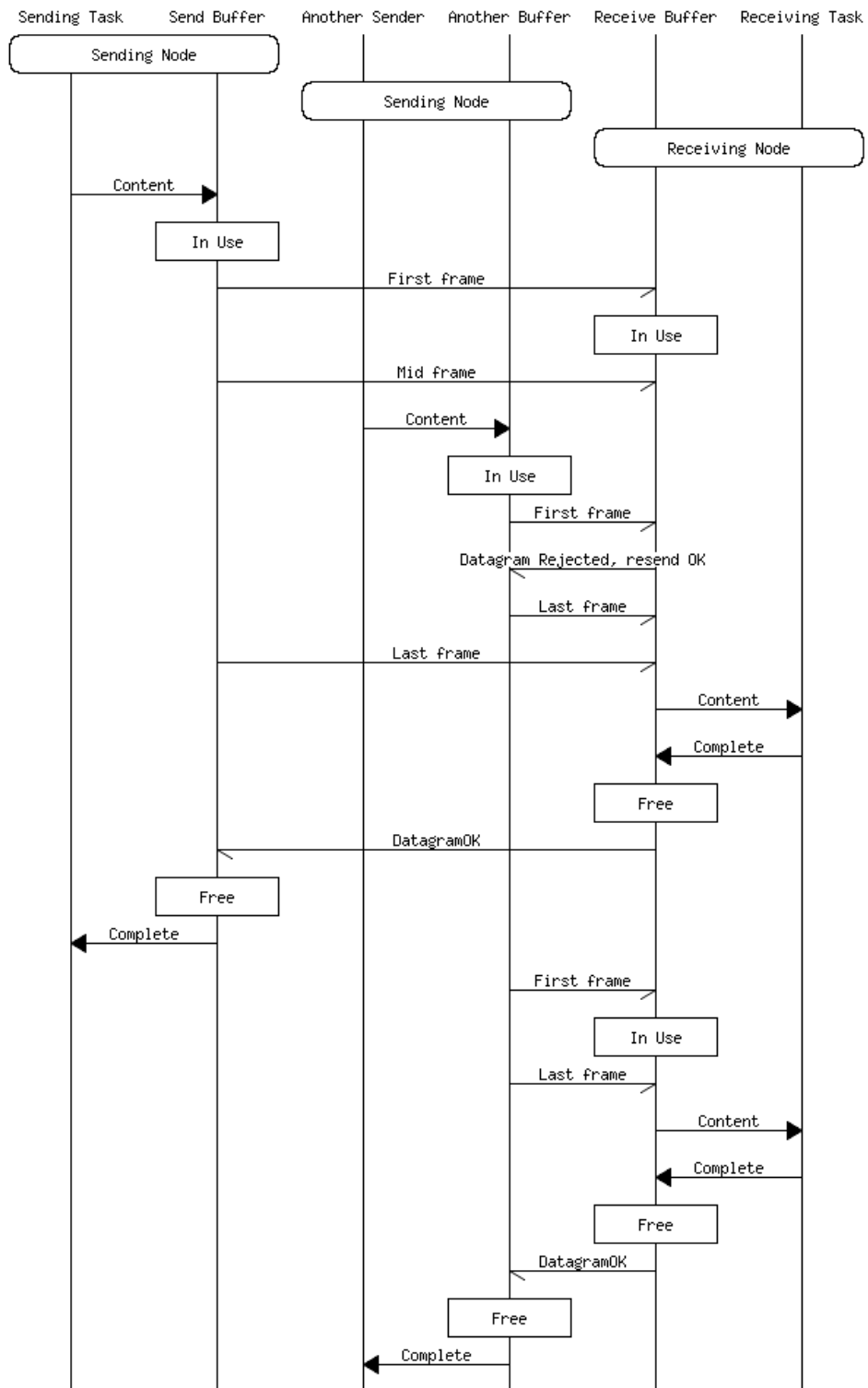

240 Example of a node receiving two overlapping datagrams, rejecting one, and then receiving the retransmission.

### 3.3.5 Command/Reply Example

245 Command Datagram →  
 ← Datagram Received OK  
 ← Reply Datagram  
 Datagram Received OK →

### 3.3.6 Back and Forth Datagram Protocol

Small nodes may have only one datagram receive buffer and one datagram transmit buffer. In that case, sending multiple commands can result in poor performance if the replies go after the next request, e.g.:

250 Command Datagram →  
 ← Datagram Received OK  
 ← Reply Datagram  
 Command Datagram →  
 Datagram Received OK →  
 255 ← Datagram Received OK  
 ← Reply Datagram  
 Datagram Received OK →

260 Note that the 2<sup>nd</sup> command was sent before the reply datagram was sent. This is valid, but nodes with only one buffer may not be able to handle that second command until the transmit buffer has been emptied by an acknowledgement. In that case, the sequence may become, e.g.:

265 Command Datagram →  
 ← Datagram Received OK  
 ← Reply Datagram  
 Command Datagram →  
 ← Datagram Rejected, Resend OK  
 Datagram Received OK →  
 Command Datagram (retransmit) →  
 ← Datagram Received OK  
 ← Reply Datagram  
 270 Datagram Received OK →

which is significantly less efficient. Better to send the positive acknowledgement to the reply datagram before sending the next command.

## 3.4 Datagram Content

275 There needs to be a method for identifying the content of a general datagram. OpenLCB is meant to be used with both very simple, low-end nodes, and high-end computers with multiple programs. In both those environments, it is inconvenient to have constraints like “the next datagram will carry...” because there might be more than one thing going on, and it is hard to write code that knows about lots of global state information. It must be possible to interleave, e.g., configuration datagrams (messages) with datagrams that are displaying messages. Therefore, most datagrams will carry information about  
 280 which conversation they are part of. We call that information “datagram content identification”.

We also want “datagram content IDs” to be small, unique, unambiguous, easily assigned, etc. To do that, there are two basic approaches:

- 285 • A one-byte ID field with a central sequential method of assignment. It is called the “Datagram Content ID”. This is small, so doesn't use much space on CAN, but requires central recording of IDs.
  - A 6-byte field assigned the same way that node unique identifiers are. The protocol designer(s) uses a unique ID they control to identify the new protocol they are defining. This takes significantly more space, particularly on CAN, but is simple to maintain and requires no central registration.
- 290 The plan is to use both. There will be a one-byte field, with certain values to escape to a two-byte field (reserved for future use), and to a six-byte fully-unique field. A separate spreadsheet is accumulating values.

### 3.5 Numerology

295 This section discusses how big the maximum datagram payload can be. This is a decision that must balance buffer size versus utility of the protocol. Memory is scarce in a small node. Although it is possible to incrementally process parts of a datagram as they arrive, in general it will be necessary to have a buffer of the maximum possible size available when a datagram is arriving. (That same buffer can be used to send datagrams, if needed.) At the same time, datagrams that are too small to contain a useful atomic message require extra coding work.

300 At the high end, what's the maximum size for a datagram, beyond which it makes sense to move to a stream? The stream startup overhead is small, so that streams can be used for even small amounts of data. The maximum datagram size must be short enough that nodes can afford to have a fixed receive-and-process buffer for datagrams allocated, unlike streams that can be too large to buffer as a whole.

305 At the low end, datagrams should go all the way down to zero bytes, because they are distinct from Events (which have a fixed 8-byte payload).

310 If one byte is used for the datagram content ID field (see 3.4 Datagram Content), the first CAN-link datagram contains 7 payload bytes (the following datagrams can contain 8). The datagram format field counts as part of the information that the datagram is transporting, though. We could make the maximum datagram size nine segments,  $(9*8) = 72-1$  data bytes, to ensure that even with a little bit of additional overhead from an application-layer protocol, say up to 6 bytes, 64 bytes of actual data can be delivered at a shot.

Alternately, because of the binary nature of addressing, a 64-byte buffer size might be more convenient than a 72-byte one, even at the cost of some lost possible capacity in the last frame.

315 For external protocols, e.g. support for LocoNet, XpressNet, DCC, etc., it is a great simplification if the datagrams can carry any basic message of the external protocol in a single datagram. Is 64 data bytes then enough? The evidence at hand suggests that 64 data bytes is more than sufficient.

320 As a balance between these, and to optimize certain layouts on CAN links, a size of 72 bytes has been selected. The OpenLCB protocols have been designed such that this can be extended to 128 bytes for specific application protocols if needed, while still maintaining backward compatibility with devices that only implement a 72-byte datagram size.

## 3.6 Future Extensions

### 3.6.1 Global Datagrams

In this version of the datagram protocol, there is no provision for multiple recipients of a single message. Transmission is strictly one-to-one. This constraint is not because of addressed nature of datagrams (making the messages globally visible is not hard), but rather the need for guaranteed buffering at the receiving node. In the future, we may want to provide one-to-many datagrams.

For this to work, the recipient will need to have a buffer into which any datagram in flight can be received. On a tiny node, those might be a scarce resource. But, without any protocol support, e.g. if datagrams were “fire and forget” like event notifications, you might need to have a very large number of those buffers. There's nothing in the protocol that prevents nodes A, B, C and D from firing off a datagram at node X at the same time, and having their CAN frames be interleaved when they arrive at X. (The stream protocol negotiates this in advance, but that requires time and resources only appropriate to large transfers) To properly receive them, X needs  $N=4$  buffers to reassemble them in this case. But how big an N is really required? The recipient cannot know, so instead we add protocol support: X can tell nodes sending it datagrams to repeat them. That way X can accept as many datagrams as it has buffers (at least one), while telling the others to “say that again, please, I wasn't paying attention the first time”.

With addressed one-to-one datagrams, a sending node knows that it has to hang onto the datagram until it receives a “Received OK” message, because if the sender receives a “Rejected, Resend OK” it needs to still have the content to resend it. The “Received OK” and “Rejected, Resend OK” are not about data loss on a link, but about buffer management in tiny nodes. Once Received OK has been received, the buffer contents are no longer needed and the buffer can be reused.

A global datagram protocol is possible where the sending node can decide, on its own, when it doesn't need to resend the datagram to nodes that were not able to receive it. For example, a node might be looking for some resource by sending a global datagram. It needs only preserve the request until it finds the resource; requests for retransmission that arrives after that can be safely ignored.

The remaining question is now the sending node knows which global datagram to retransmit. If it sends global datagram A, then immediately sends global datagram B, it has to know which to resend from just the resend request message (or, if they are idempotent, it could send both, but this gets out of hand). This needs to be built into the datagram protocol extension in a higher-protocol-independent way.

### 3.6.2 CAN Extensions

Although Bosch has proposed a new standard called CAN-FD<sup>2</sup>, which permits frames as large as 64 bytes, we have decided not to reduce maximum size of a datagram to fit easily within this frame size. There are good reasons to retain the possibility of larger-than-64-byte datagrams, e.g. so you can have a command header of 8 bytes on the front of 64 data bytes. Should CAN-FD come into general use, datagrams will just use the longer frames in the current system for breaking Datagram Content messages into segments.

15 <sup>2</sup>[http://www.bosch-semiconductors.de/media/pdf\\_1/canliteratur/can\\_fd.pdf](http://www.bosch-semiconductors.de/media/pdf_1/canliteratur/can_fd.pdf)

### 3.7 Implementation Notes

360 A resource-constrained node can get along with a single datagram buffer for both sending and receiving, but this may require that the node be able to abandon and recreate a datagram that it is trying to transmit. This can happen when, e.g.:

- Node A creates a datagram for node B in its buffer and starts to send it.
- Before starting to receive the datagram from A, node B creates a datagram for Node A in its  
365 buffer and starts to send it.

Both datagrams now need a place to put the incoming datagram, but only have one buffer in this example. They can both send “Rejected, Resend OK”, but then their peer will just repeat the attempt to send. At least one has to drop the content from its datagram buffer and receive the datagram to avoid deadly embrace. This can also happen in other contexts too, but only when sharing a buffer between  
370 transmit and reception. It is therefore easiest for an implementation to provide for two buffers if it is likely to send and receive datagrams asynchronously.

The datagram protocol allows all nodes to reject a datagram when it has been totally received. CAN and other wire protocols, because they require fragmentation of the datagram into smaller segments, therefore also allow an early rejection of a datagram. This mechanism can help keep buffers clear, but it  
375 is not required that CAN implementations use this mechanism.

## Table of Contents

1 Introduction.....	1
2 Annotations to the Standard.....	1
2.1 Introduction.....	1
2.2 Intended Use.....	1
2.3 References and Context.....	1
2.4 Message Formats.....	1
2.4.1 Datagram Content.....	1
2.4.2 Datagram Received OK.....	2
2.4.3 Datagram Rejected.....	3
2.4.3.1 Error Codes.....	3
2.5 States.....	4
2.6 Interactions.....	4
2.6.1 Normal Transmission.....	4
2.6.2 Rejected Transmission.....	4
2.7 Adaptation to CAN Transport.....	5
2.7.1 CAN Message Formats.....	5
2.7.2 CAN States.....	5
2.7.3 CAN Interactions.....	5
2.7.3.1 Normal Transmission.....	5
2.7.3.2 Rejected Transmission.....	6
3 Background Information.....	6
3.1 Use Cases.....	6
3.2 Discussion.....	7
3.3 Examples.....	7
3.3.1 Normal CAN case.....	7
3.3.2 Short CAN datagram case.....	8
3.3.3 Rejected short CAN datagram case.....	8
3.3.4 Rejected interleaved CAN datagram case.....	9
3.3.5 Command/Reply Example.....	10
3.3.6 Back and Forth Datagram Protocol.....	10
3.4 Datagram Content.....	10
3.5 Numerology.....	11
3.6 Future Extensions.....	12
3.6.1 Global Datagrams.....	12
3.6.2 CAN Extensions.....	12
3.7 Implementation Notes.....	13