



NMRA Standard	
PluX Decoder Interface	
Jul 7, 2021	S-9.1.1.4

1 General

1.1 Introduction and Intended Use (Informative)

5 This standard defines a uniform multi-pole interface for vehicles for safe and quick installation or exchange of electronic modules (vehicle and function decoder or SUSI module, hereinafter referred to as decoder) for the purpose of control via Digital Command Control systems.

1.2 References

This standard should be interpreted in the context of the following NMRA Standards, Technical Notes, and Technical Information.

1.2.1 Normative

- 10
- S-9.1.1 DCC Interfaces, which specifies general DCC interface requirements

1.2.2 Informative

- 15
- TN-9.1.1.4 PluX Decoder Interface, which provides commentary on the PluX decoder interface.
 - TI-9.1.1 Sources for Connectors for DCC, which provides a list of manufacturer part numbers for DCC interface connectors.
 - TI-9.2.3 Serial User Standard Interface for DCC, which provides information on SUSI.
 - RCN-122 Decoder Interface PluX, with which this standard is intended to be in harmony.
 - NEM 658 Electrical Interface PluX, with which this standard is intended to be in harmony.

1.2.3 Description of the Interface

20 The interface supports the connection of a motor, up to 9 function outputs, 3 logic level input/outputs, capacitor connections and loudspeaker connections. The installation space and the size of the decoder are part of the interface. Vehicles with a factory-installed interface and decoder with the interface according to this standard must be clearly marked on the packaging that they adhere PluX22 or PluX16.

25 The interface is defined for plugging the decoder directly into the vehicle system board. A connection via cable is not provided and such a design does not correspond with this standard.

1.3 Terminology

Term	Definition
Vehicle	Mobile model railroad device. This includes locomotives and other rolling stock.
Decoder	DCC receiver for controlling vehicle animation.
System Board	Electronic circuit board that is considered part of the vehicle which a decoder is intended to be plugged into. Also sometimes called a motherboard.
Train Bus	Serial User Standard Interface (SUSI)

30 1.4 Requirements

To meet this standard all mechanical and electrical values mentioned must be met and respected, unless otherwise noted. It is not necessary to implement all connections of the interface. The connections belonging to unimplemented features must remain unconnected. This applies to vehicles as well as for other devices that use this interface.

35 NEM-658 has in the past defined PluX12 and PluX8 interfaces. These are now deprecated by MOROP for new vehicles. These past definitions are not part of this standard.

2 Mechanical Properties

40 On the vehicle side, the interface consists of a 16 or 22-pin double-row set of sockets, with a grid dimension of 1.27 mm to match that on the decoder. To ensure correct orientation of the decoder in the socket pin 11 is omitted on the decoder and the associated socket on the vehicle is blocked.

The pins have a length of a minimum of 3 mm, a maximum of 4 mm and either a square profile with 0.40 mm edge length or a round profile with a diameter of 0.43 mm. Pins and sockets have a gold-plated contact surface and a contact load of 1 A maximum.

PluX22 uses all 22 pins, PluX16 uses pins 3 to 18 only.

45 Note that for historical reasons the numbering of the pins on the PluX standard is not the same as that on the 21MTC decoder; see figure 1 below.

2.1 Dimensional requirements

The side of the decoder with the connector pins is defined as the underside. The maximum dimensions of the decoder are as given in the table below. Refer also to figure 1.

50

Table 1: Decoder dimensions

Key on Figure 1	Description	PluX22	PluX16
a	Max length of decoder	30.0mm	20.0mm
b	Max width of decoder	16.0mm	11.0mm
c	Max decoder thickness	6.0mm	4.2mm
d	Connector centre line from decoder edge	3.6mm (exactly)	
e	Vehicle circuit board thickness	1.0mm	
	Decoder circuit board thickness	1.0mm	
	Free pin length from decoder connector	3.0mm	
	Max thickness of components on underside of decoder	3.0mm	

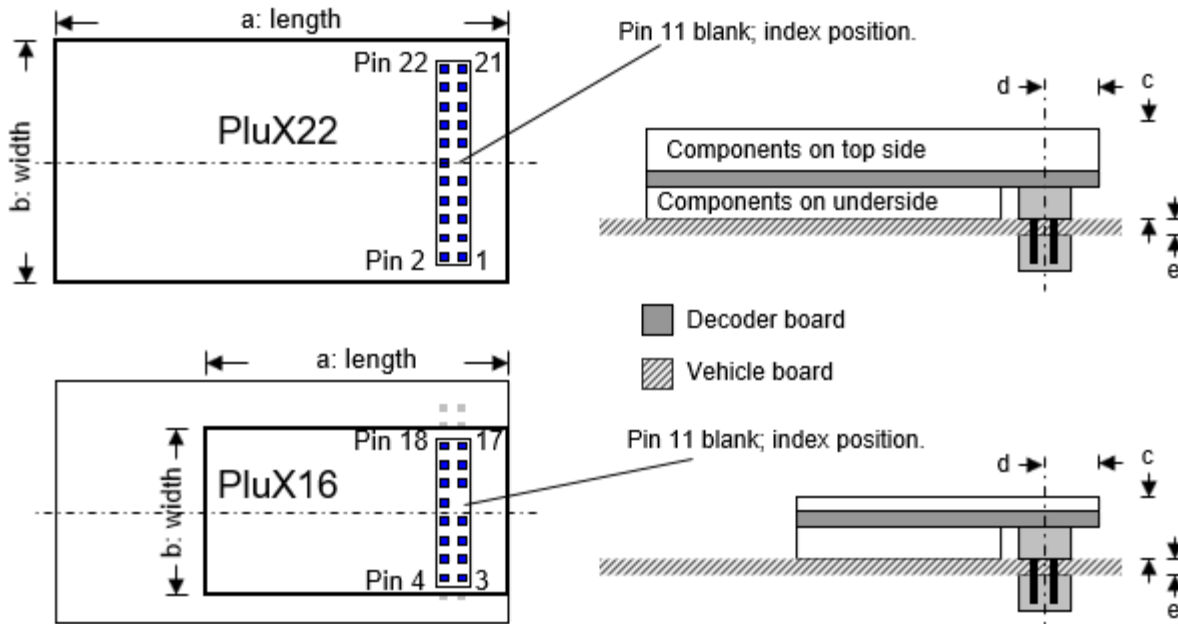

55 Figure 1: PluX22 and PluX16 dimensions.

2.2 Vehicle requirements

The installation space in the vehicle must be such that a decoder with maximum allowed dimensions can be inserted or removed without difficulty. It should also be possible to insert and remove the decoder without the need for tools.

60 Two variants of the vehicle socket are defined.

2.2.1 Compact Version

The compact socket offers the lowest possible overall height by placing the vehicle socket on the underside of the vehicle circuit board. The decoder sits on the vehicle circuit board. This area of the circuit board must be kept free of components. The maximum thickness of the vehicle board is 1 mm in this variant. The board has holes in it for the pin header to be inserted through the board from above; no hole shall be made at the pin 11 position. There must be enough space under the socket

65 strip for the maximum pin length to be accepted.

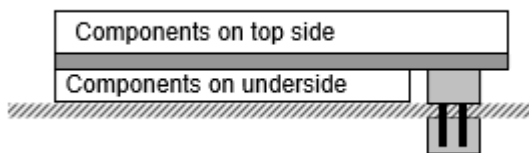

Figure 2: Compact decoder installation.

2.2.2 Tall Version

If there is enough height in the vehicle above the circuit board the tall version can be used. Here the socket strip is located on the top of the vehicle circuit board, with holes in the board to ensure that the pins on the decoder can be fully inserted in the socket. The vehicle circuit board should not have

75 components in the area covered by the decoder which are taller than the connector used. The connector socket shall have the pin 11 position blocked.

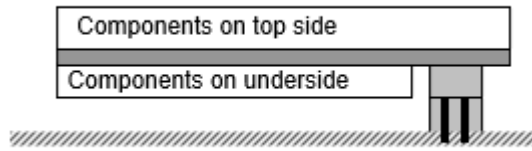

Figure 3: Tall decoder installation

3 Electrical Characteristics

80 Manufacturers of this decoder must specify the maximum current allowed to be drawn for each output and input, noting the per-pin maximum in section 2.

3.1 Pin Assignments

Table 2: Contact assignment and description of each contact.

Plux22	Plux16	Name	Description	Group
1		GPIO / C	General Input/Output	4
2		Aux 3	Function 3 output	5
3	3	GPIO / B	Train bus clock, alternatively AUX 8	7
4	4	GPIO / A	Train bus data, alternatively AUX 9	7
5	5	GND	Decoder ground, tap after rectifier	
6	6	Cap. +	Storage capacitor plus (not decoder plus)	2
7	7	F0f	Forward direction of travel light	5
8	8	Motor1	Motor connection 1 plus / forward	3
9	9	V +	Decoder Plus, tap after rectifier	
10	0	Motor2	Motor connection 2 minus / reverse	3
11	11	index	not used, decoder orientation.	
12	12	Track 1	Track pick-up right rail when in the forward direction of travel	1
13	13	F0r	Reverse direction light	5
14	14	Track2	Track pick-up left rail when in the forward direction of travel	1
15	15	LS / A	Speaker connector A	6
16	16	AUX1	Function 1 output	5
17	17	LS / B	Speaker connection B	6
18	18	AUX2	Function 2 output	5
19		AUX4	Function 4 output	5
20		AUX5	Function 5 output	5
21		AUX6	Function 6 output	5
22		AUX7	Function 7 output	5

85 Connections that are not used on the vehicle side should be routed to soldering points on the vehicle circuit board.

3.2 Description of Groups

See table 1 above.

- 90 Group 1: For 3-rail AC operation, track 1 (pin 12) is connected to the power take-off for the center conductor and track 2 (pin 14) is connected to the power take-off for the wheels.
- Group 2: Cap. + Is specially designed for connecting storage capacitors. This plus connection should be switchable in order to switch off the storage capacitor, for example when on the programming track. It carries a maximum of the track voltage to V +.
- 95 Group 3: For AC motors, Motor1 (pin 8) is field coil A, Motor2 (pin 10) is field coil B.
- Group 4: GPIO / C can be output or input. As an input, it must be switched to GND. The input resistance should be approximately 100kΩ. It has TTL-compatible logic levels (table 3) as output and can be loaded with a maximum of 0.5 mA.
- 100 Group 5: When switched on, these outputs are connected to GND on the decoder side. The voltage for the switched load results from the track voltage at V +. If the rear lights are connected separately from the headlights in the vehicle, the rear lights from driver's cab 1 are switched with Aux1 (pin 16) and those from driver's cab 2 with Aux2 (pin 18).
- 105 Group 6: The effective impedance of the speaker(s), as observed by the decoder, is 4Ω - 8Ω, and must be documented by the decoder manufacturer. Impedance of factory installed speakers must be documented by the vehicle manufacturer.
- Group 7: The processor pins of the train bus are brought out directly with a series resistance of max. 470 Ω. The levels correspond to TTL-compatible logic levels (Table 2). These connections can also be used as function outputs with logic level.

	Voltage level Decoder output	Input load switch
Function switched off	<= 0.4 volts	<= 0.8 volts
Function switched on	> = 2.4 volts	> = 2.0 volts

110 Table 2: Voltage level at the GPIO connections of the decoder

It should be noted that when the decoder processor is started, uncontrolled states including a high-resistance state at the outputs with logic level can occur. Critical hardware on the locomotive board must be secured accordingly.

- 115 If a PluX16 decoder is plugged into a vehicle with a Plux22 interface, the functions on pins 1, 2 and 19 to 22 cannot be controlled. If there is enough space in a vehicle with a PluX16 interface and the corresponding holes are available in the compact installation variant, a PluX22 decoder can also be plugged in. This can be useful if, for example, a company offers a (sound) decoder only with a PluX22 interface, but the additional functions are not required on the vehicle side.

4 Operation without a Decoder

- 120 When operating without a decoder, a jumper plug must be used, which connects at least the connections of track 1 (pin 12) with motor 1 (pin 8) and track 2 (pin 14) with motor 2 (pin 10). See figure 4.

- 125 If there is vehicle lighting, F0f (pin 7) must also be connected to track 2 (pin 14) and F0r (pin 13) to track 1 (pin 12). The connection V + (pin 9) is to be supplied via two diodes from the track connections.

Depending on the wiring of the function outputs in the vehicle, the vehicle manufacturer can produce a jumper plug specific to the vehicle that connects other outputs. In the middle picture the

© 2021 National Model Railroad Association, Inc.

outputs F0f and F0r are controlled depending on the direction; In the right picture, the functions AUX1 and AUX2 are also always switched on.

130

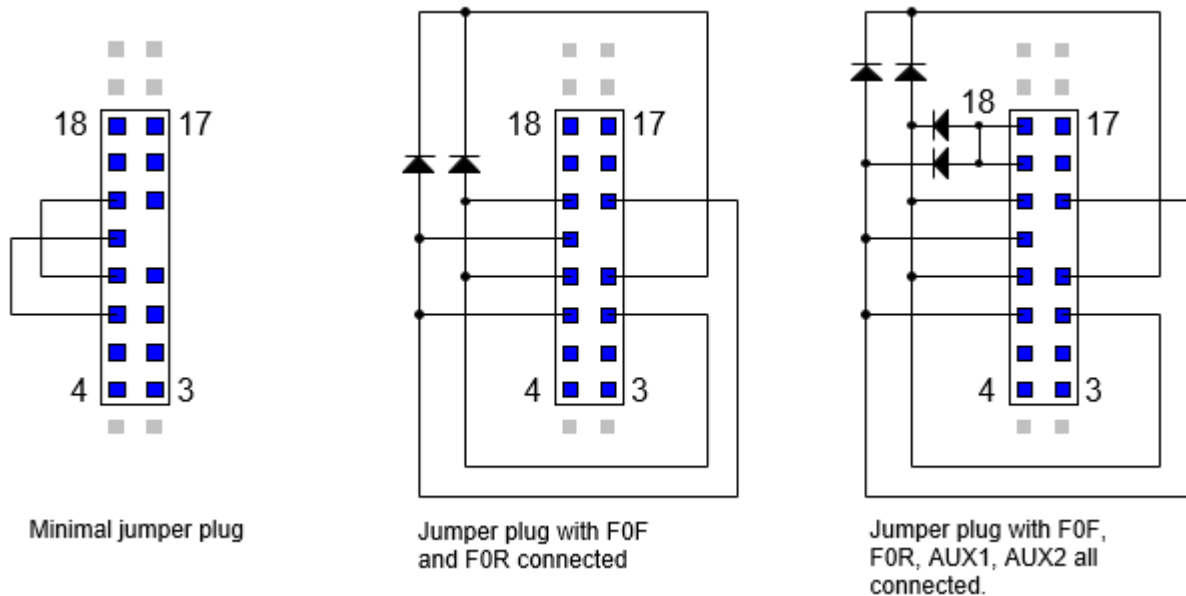

Figure 4: Blanking Plug arrangements.

5 Use of the interface with SUSI

The Plux22 interface can also be used as a SUSI interface according to TI 9.2.3. In this case, only four signals are used:

135

- GND (pin 5)
- V + (pin 9)
- train bus clock (pin 3)
- train bus data (pin 4)

140

Which will be connected directly to the drive or function decoder. In particular, the track connections are not connected when used as a SUSI interface. All other connections can be used for the functions of the SUSI module.

6 Document History

Date	Description
16-March 2021	First Version
7-July-2021	Line 67 changed provided to accepted for clarity.

145

Important Notices and Disclaimers Concerning NMRA Standards Documents

The Standards (S), Recommended Practices (RP), Technical Note (TN), and Technical Information (TI) documents of the National Model Railroad Association ("NMRA Standards documents") are made available for use subject to important notices and legal disclaimers. These notices and disclaimers, or a reference to this page, appear in all standards and may be found under the heading "Important Notices and Disclaimers Concerning NMRA Standards Documents."

Notice and Disclaimer of Liability Concerning the Use of NMRA Standards Documents

NMRA Standards documents are developed within the Standards and Conformance Department of the NMRA in association with certain Working Groups, members, and representatives of manufacturers and sellers. NMRA develops its standards through a consensus development process, which brings together volunteers representing varied viewpoints and interests to achieve the final product. NMRA Standards documents are developed by volunteers with modeling, railroading, engineering, and industry-based expertise. Volunteers are not necessarily members of NMRA, and participate without compensation from NMRA.

NMRA does not warrant or represent the accuracy or completeness of the material contained in NMRA Standards documents, and expressly disclaims all warranties (express, implied and statutory) not included in this or any other document relating to the standard or recommended practice, including, but not limited to, the warranties of: merchantability; fitness for a particular purpose; non-infringement; and quality, accuracy, effectiveness, currency, or completeness of material. In addition, NMRA disclaims any and all conditions relating to results and workmanlike effort. In addition, NMRA does not warrant or represent that the use of the material contained in NMRA Standards documents is free from patent infringement. NMRA Standards documents are supplied "AS IS" and "WITH ALL FAULTS."

Use of NMRA Standards documents is wholly voluntary. The existence of an NMRA Standard or Recommended Practice does not imply that there are no other ways to produce, test, measure, purchase, market, or provide other goods and services related to the scope of the NMRA Standards documents. Furthermore, the viewpoint expressed at the time that NMRA approves or issues a Standard or Recommended Practice is subject to change brought about through developments in the state of the art and comments received from users of NMRA Standards documents.

In publishing and making its standards available, NMRA is not suggesting or rendering professional or other services for, or on behalf of, any person or entity, nor is NMRA undertaking to perform any duty owed by any other person or entity to another. Any person utilizing any NMRA Standards document, should rely upon their own independent judgment in the exercise of reasonable care in any given circumstances or, as appropriate, seek the advice of a competent professional in determining the appropriateness of a given NMRA Standards documents.

IN NO EVENT SHALL NMRA BE LIABLE FOR ANY DIRECT, INDIRECT, INCIDENTAL, SPECIAL, EXEMPLARY, OR CONSEQUENTIAL DAMAGES (INCLUDING, BUT NOT LIMITED TO: THE NEED TO PROCURE SUBSTITUTE GOODS OR SERVICES; LOSS OF USE, DATA, OR PROFITS; OR BUSINESS INTERRUPTION) HOWEVER CAUSED AND ON ANY THEORY OF LIABILITY, WHETHER IN CONTRACT, STRICT LIABILITY, OR TORT (INCLUDING NEGLIGENCE OR OTHERWISE) ARISING IN ANY WAY OUT OF THE PUBLICATION, USE OF, OR RELIANCE UPON ANY STANDARD OR RECOMMENDED PRACTICE, EVEN IF ADVISED OF THE POSSIBILITY OF SUCH DAMAGE AND REGARDLESS OF WHETHER SUCH DAMAGE WAS FORESEEABLE.

Translations

NMRA's development of NMRA Standards documents involves the review of documents in English only. In the event that an NMRA Standards document is translated, only the English version published by NMRA is the approved NMRA Standards document.

Official Statements

A statement, written or oral, that is not processed in accordance with NMRA policies for distribution of NMRA communications, or approved by the Board of Directors, an officer or committee chairperson, shall not be considered or inferred to be the official position of NMRA or any of its committees and shall not be considered to be, nor be relied upon as, a formal position of NMRA.

Comments on Standards

Comments for revision of NMRA Standards documents are welcome from any interested party, regardless of membership. However, **NMRA does not provide interpretations, consulting information, or advice pertaining to NMRA Standards documents.**

Suggestions for changes in documents should be in the form of a proposed change of text, together with appropriate supporting comments. Since NMRA standards represent a consensus of concerned interests, it is important that any responses to comments and questions also receive the concurrence of a balance of interests. For this reason, NMRA, its departments, Working Groups or committees cannot provide an instant response to comments, or questions except in those cases where the matter has previously been addressed. For the same reason, NMRA does not respond to interpretation requests. Any person who would like to participate in evaluating comments or in revisions to NMRA Standards documents may request participation in the relevant NMRA working group.

Laws & Regulations

Users of NMRA Standards documents should consult all applicable laws and regulations. Compliance with the provisions of any NMRA Standards document does not constitute compliance to any applicable regulatory requirements. Implementers of the standard are responsible for observing or referring to the applicable regulatory requirements. NMRA does not, by the publication of NMRA Standards documents, intend to urge action that is not in compliance with applicable laws, and NMRA Standards documents may not be construed as doing so.

Copyrights

NMRA Standards documents are copyrighted by NMRA under US and international copyright laws. They are made available by NMRA and are adopted for a wide variety of both public and private uses. These include both use, by reference, in laws and regulations, and use in private self-regulation, standardization, and the promotion of modeling, structural and engineering practices and methods. By making NMRA Standards documents available for use and adoption by public authorities and private users, NMRA does not waive any rights in copyright to the NMRA Standards documents.

IMPORTANT NOTICE

NMRA Standards documents do not guarantee or ensure safety, security, health, or environmental protection, or ensure against interference with or from other systems, devices or networks. NMRA Standards documents development activities consider research and information presented to the standards development group in developing any safety recommendations. Other information about safety practices, changes in technology or technology implementation, or impact by peripheral systems also may be pertinent to safety considerations during implementation of the standard. Implementers and users of NMRA Standards documents are responsible for determining and complying with all appropriate safety, security, environmental, health, and interference protection practices and all applicable laws and regulations.